

Check Valves

HTCV08U- COA Valve Series

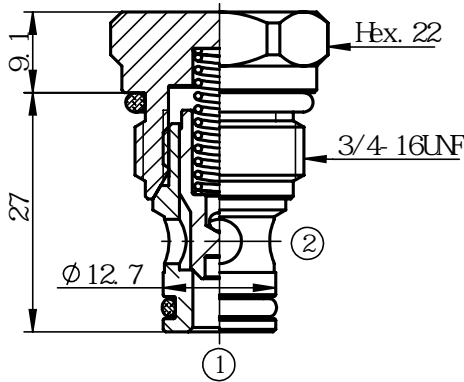

A screw-in, direct acting, poppet type check valve. Main use is as a blocking or load-holding device. The valve allows flow passage from port 1 to 2: the cartridge has a fully guided check which is spring-biased closed until sufficient pressure is applied at port 1 to open to 2. The flow is blocked in the opposite direction (2 to 1).



Poppet is hardened and ground to guarantee minimal wear and to extend service life. All external surfaces are zinc plated and corrosion-proof. All valve parts are made of high strength steel. Compact size. Industry common cavity.



	420 bar
	50l/min
	See table in Ordering code
	0,10 cm ³ / min @ 10 bar 0,10 cm ³ / min @ 420 bar
	Zn/Fe - standard Zn/Ni
	No restrictions
	40- 45 Nm, Hex. 22
	1-2 see the last page 1-2
Weight	0.063 kg
	-30° C to 110° C
Fluids	Mineral - based or synthetics with lubricating properties
Viscosities	7,4 to 420 cSt
	ISO VG 46 cSt
	20/18/15 ISO 4406 (maximum filtration admitted)

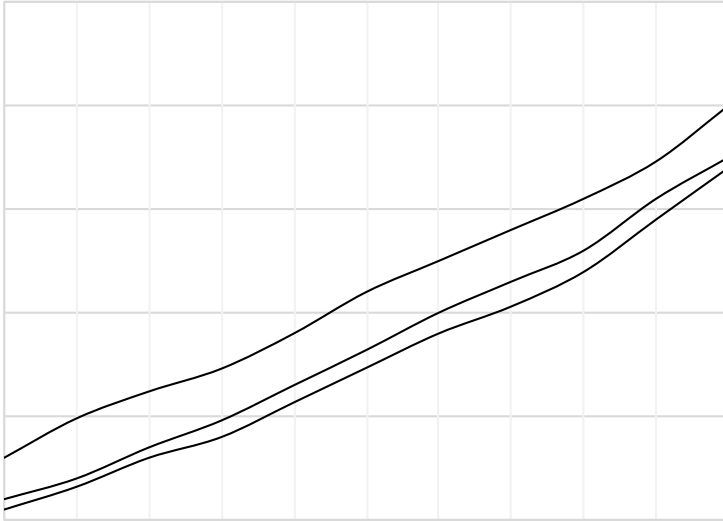

P/Q Toil=40° C 46cSt

Note: The performance chart illustrates flow handling capacity. P/Q curves are recorded at Toil=40° C and 46cSt.

